

Packaged Valve Trains



The ETTER Engineering packaged valve trains are complete packaged solutions, designed to meet your specific needs whether you are an OEM or End-User of the equipment. All safety shut off valves and switches used are FM approved. All trains are leak tested and operationally checked prior to shipping, reducing your burden and risk.

ETTER Offers:

- Custom design to meet your specific needs
- Sizes available from 3/8" NPT to 6" Flanged
- Ventless systems available for easy install
- Code compliance including FM, NFPA, and IRI
- Built to meet local and international codes



ETTER's Valve Train Series:

- EVT1000 - Gas valve train module per NFPA-86
- EVT2000 - Pilot gas valve train per NFPA-86
- EVT3000 - Complete gas valve train per NFPA-86
- EVT4000 - Gas valve train module for boilers per NFPA-85
- EVT5000 - Pilot gas valve train for boilers per NFPA-85
- EVT6000 - Complete gas valve train for boilers per NFPA-85
- EVT7000 - Oil valve train module for boilers per NFPA-85
- EVT8000 - Pilot oil valve train for boilers per NFPA-85
- EVT9000 - Complete oil valve train for boilers per NFPA-85
- ERM - Regulator module for valve trains
- EMM - Metering module for valve trains
- EFM - Flow control module for valve trains

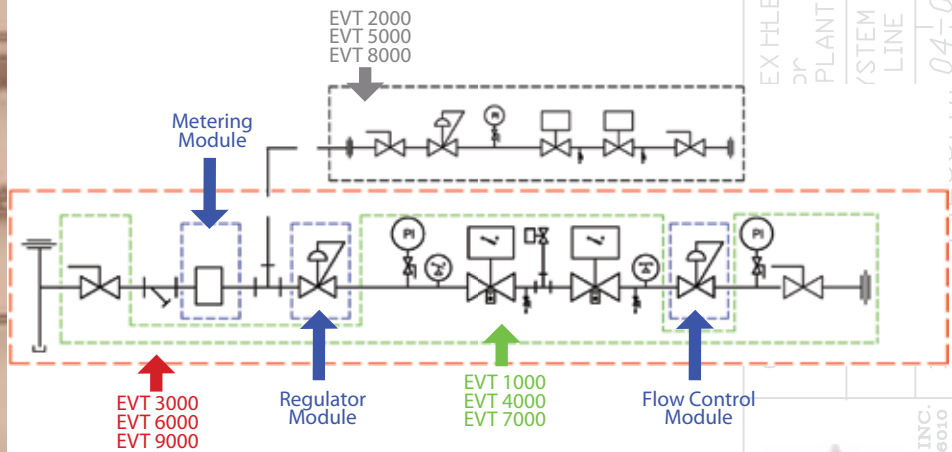
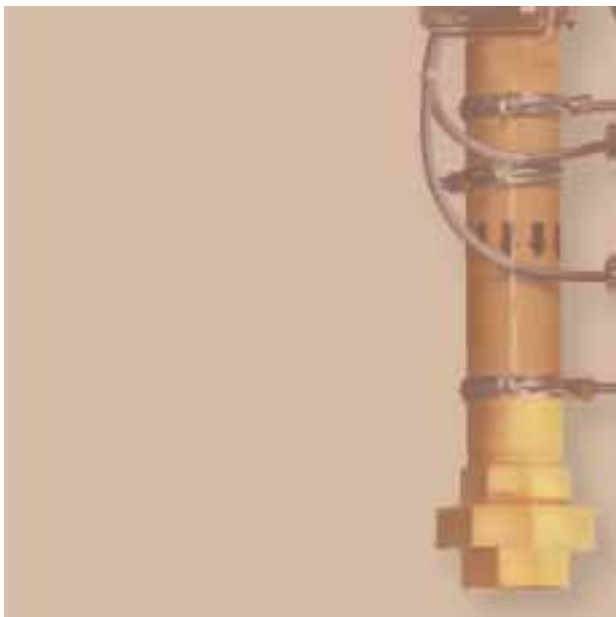

See individual sales brochure and configurator for each "series" of valve trains. Some optional equipment shown, and certain configurator selections will change schematic.

